



FORGE STEEL

GATE, GLOBE & CHECK VALVES



WWW.PARSREGULATOR.COM

S.W (NPT) Gate Valve

CL 800

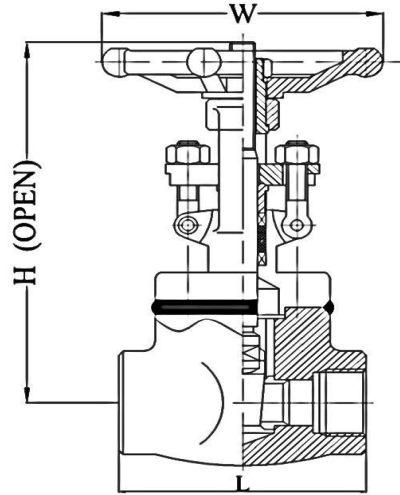
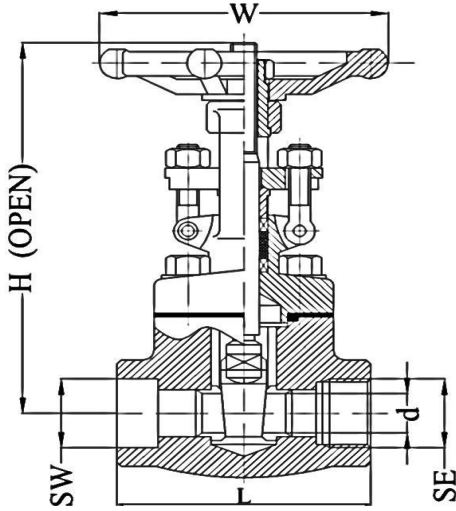

Features and Applications

- Reduced or full port
- Construction :B.B & W.B , OS & Y
- Gasket: Stainless Steel+graphite
- Socket Welding & Threaded ends
- Material for hard trim is Depend on Client notice & oeprating condition
- B.B : BOLTED BONNET
- W.B : WELDED BONNET
- Design & manufacture: API 602 & ANSI B 16.34
- Socket welding dimension :ANSI B 16.11
- Screw end dimension :ANSI B1.20.1
- Inspect and test :API 598
- Body material:A105,LF2,F5,F11,F22,F304L,F316L
- All dimensions could be considered as reference.

Dimensions

Normal diameter	Reduced port	mm(in)	8(1/4)	10(3/8)	15(1/2)	20(3/4)	25(1)	32(11/4)	40(11/2)	50(2)	-
	Full port	mm(in)	-	-	10(3/8)	15(1/2)	20(3/4)	25(1)	32(11/4)	40(11/2)	50(2)
d	mm		7	7	10	12.7	18	23	28.5	36	43
L	mm		79	79	79	92	111	120	120	140	170
H(Open)	mm		166	166	166	169	193	230	246	283	332
w	mm		100	100	100	100	125	160	160	180	200
Weight	B.B	Kg	2.5	2.4	2.3	2.6	4.5	5.9	7.2	11.2	18.8
	W.B	Kg	-	-	2.4	2.7	4.6	6.1	7.4	11.4	19.1

E-MAIL : info@parsregulator.com
parsregulator@yahoo.com

www.parsregulator.com

Tel : 88 30 77 66
Fax: 88 83 41 40

FORGED STEEL VALVE SERIES

S.W (NPT) Gate Valve

CL 1500

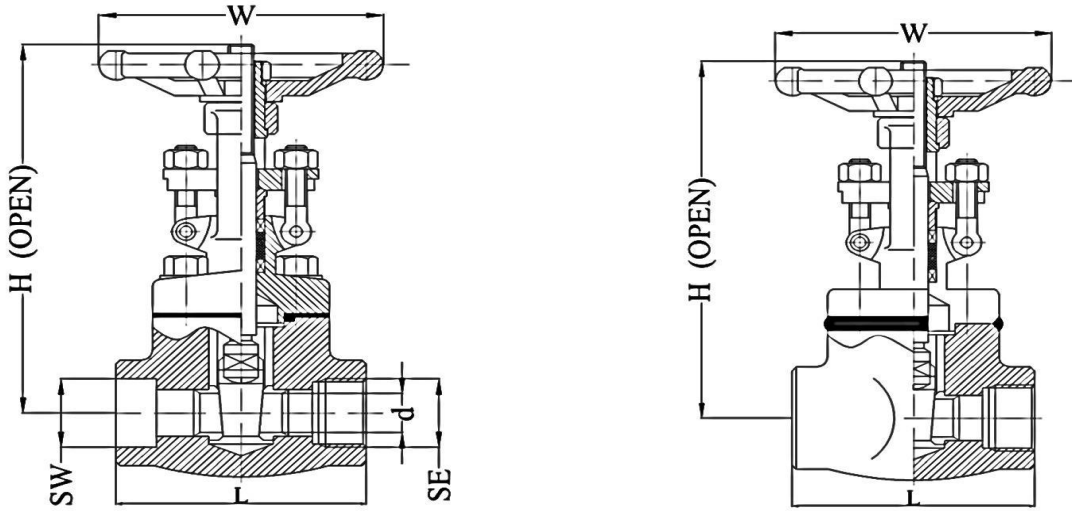

Features and Applications

- Full port
- Construction :BB & W.B ,OS&Y
- Gasket:Stainless steel + graphite
- Socket Welding & threaded ends
- Material for hard trim is depend on client notice & oerating condition
- B.B : BOLTED BONNET
- W.B : WELDED BONNET
- Design & manufacture :API 602 & ANSI B 16.34
- Socket welding dimension :ANSI B 16.11
- Screw and dimension :ANSI B 1.20.1
- inspect and test :API 598
- Body material:A105,LF2,F5,F11,F22,F304L,F316L
- All dimensions could be considered as reference.

Dimensions

Normal diameter	mm(in)	10(3/8)	15(1/2)	20(3/4)	25(1)	32(11/4)	40(11/2)	50(2)	
d	mm	10	12.7	18	23	28.5	36	43	
L	mm	79	92	111	120	120	140	170	
H(Open)	mm	170	193	230	246	283	325	334	
w	mm	100	100	125	160	160	180	200	
Weight	B.B	Kg	4.7	4.7	6.8	9.0	12.4	17.5	18.0
	W.B	Kg	4.8	4.8	6.9	9.2	12.6	17.7	17.9

info@parsregulator.com
parsregulator@yahoo.com

www.parsregulator.com

Tel : 88 30 77 66
Fax: 88 83 41 40

FORGED STEEL VALVE SERIES

S.W (NPT) Globe Valve

CL 800

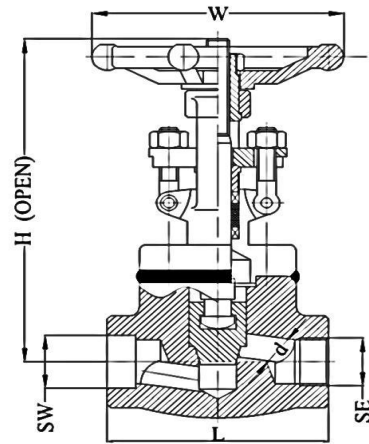
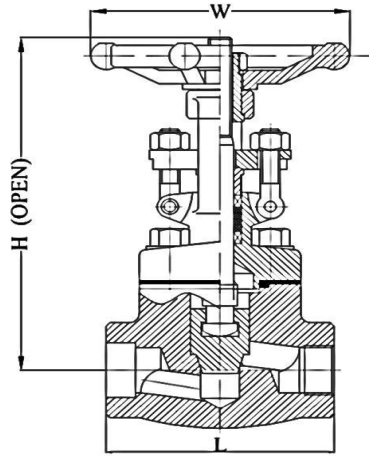

Features and Applications

- Reduced or Full port
- Construction :B.B & W.B ,OS&Y
- Gasket:Stainless steel + graphite
- Socket Welding & threaded ends
- Integral seat
- Design & manufacture :API 602 & ANSI B 16.34
- B.B : BOLTED BONNET
- W.B : WELDED BONNET
- Socket welding dimension :ANSI B 16.11
- Screw end dimension :ANSI B 1.20.1 (NPT)
- inspect and test :API 598
- Body material:A105,LF2,F5,F11,F22,F304L,F316L
- All dimensions could be considered as reference.

Dimensions

Normal diameter	Reduced port	mm(in)	8(1/4)	10(3/8)	15(1/2)	20(3/4)	25(1)	32(11/4)	40(11/2)	50(2)	-
	Full port	mm(in)	-	-	10(3/8)	15(1/2)	20(3/4)	25(1)	32(11/4)	40(11/2)	50(2)
d	mm	mm	8	10	11	13	18	23	28.5	33	43
L	mm	mm	79	79	79	92	111	120	152	172	220
H(Open)	mm	mm	166	166	166	175	206	228	262	300	340
w	mm	mm	100	100	100	100	125	160	160	180	240
Weight	B.B	Kg	2.6	2.5	2.4	2.6	4.5	5.9	8.3	12.4	20
	W.B	Kg	-	-	2.5	2.7	4.7	6.1	8.5	12.6	20.4

info@parsregulator.com
parsregulator@yahoo.com

www.parsregulator.com

Tel : 88 30 77 66
Fax: 88 83 41 40

FORGED STEEL VALVE SERIES

S.W (NPT) Globe Valve

CL 1500

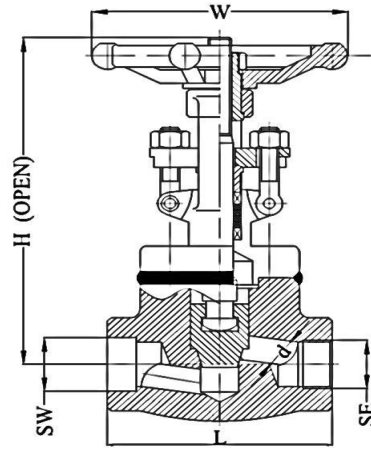
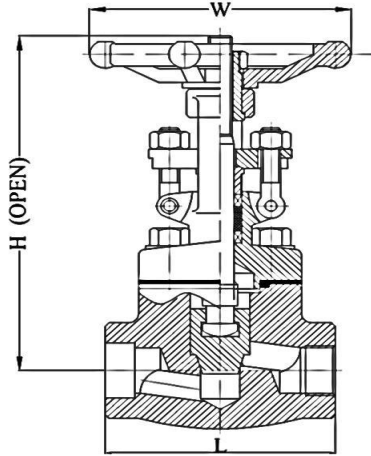

Features and Applications

- Construction : BB & W.B ,OS&Y
- Gasket:Stainless steel + graphite
- Socket Welding & threaded ends
- Integral seat
- Design & manufacture: ANSI B 16.34 , API 602
- B.B : BOLTED BONNET
- W.B : WELDED BONNET
- Socket welding dimension :ANSI B 16.11
- Screw end dimension :ANSI B 1.20.1 (NPT)
- inspect and test :API 598
- Body material:A105,LF2,F5,F11,F22,F304L,F316L
- All dimensions could be considered as reference.

Dimensions

Normal diameter	mm(in)	10(3/8)	15(1/2)	20(3/4)	25(1)	32(11/4)	40(11/2)	50(2)	
d	mm	10	13	18	23	29	33	43	
L	mm	79	92	111	120	152	172	220	
H(Open)	mm	166	170	193	230	246	283	325	
w	mm	100	100	125	160	160	180	200	
Weight	B.B	Kg	4.8	4.7	4.7	6.3	8.8	12.4	17.5
	W.B	Kg	4.5	4.1	4.1	6.7	9.0	12.1	17

info@parsregulator.com
E-MAIL : parsregulator@yahoo.com

www.parsregulator.com

Tel : 88 30 77 66
Fax: 88 83 41 40

FORGED STEEL VALVE SERIES

S.W (NPT) Check Valve

CL 800

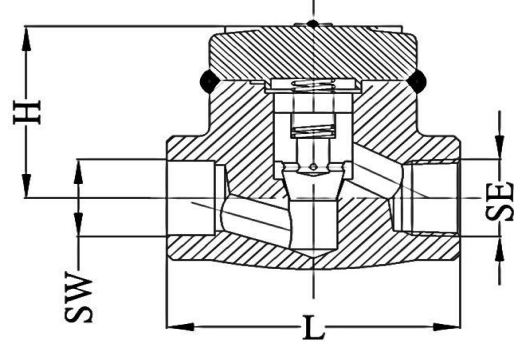
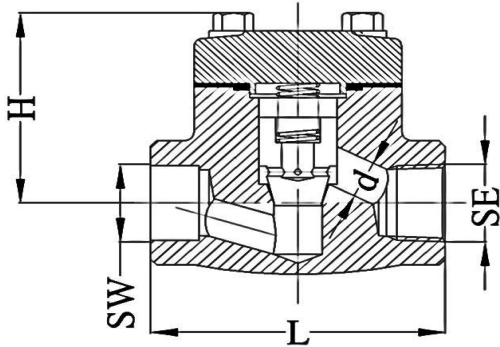

Features and Applications

- Reduced or Full port
- Construction :B.C & W.C ,lift check valve
- Gasket:Stainless steel + graphite
- Socket Welding & threaded ends
- Integral seat
- Socket welding dimension :ANSI B 16.11
- Screw end dimension: ANSI B 1.20.1(NPT)
- Design & manufacture : ANSI B16.34,API 602
- Inspect and test: API 598
- Body material: A105,LF2,F5,F11,F22,F304L,F316L
- All dimensions could be considered as reference.

Dimensions

Normal diameter	Reduced port	mm(in)	8(1/4)	10(3/8)	15(1/2)	20(3/4)	25(1)	32(11/4)	40(11/2)	50(2)	-
	Full port	mm(in)	-	-	10(3/8)	15(1/2)	20(3/4)	25(1)	32(11/4)	40(11/2)	50(2)
d	mm		7	7	11	13	18	23	28	33	42
L	mm		79	79	79	92	111	120	152	172	220
H	mm		62	62	62	63	78	82	102	120	147
Weight	Kg		1.5	1.4	1.2	1.4	2.3	3.9	5.6	8.9	12.5

info@parsregulator.com
E-MAIL : parsregulator@yahoo.com

www.parsregulator.com

Tel : 88 30 77 66
Fax: 88 83 41 40

FORGED STEEL VALVE SERIES

S.W (NPT) Check Valve

CL 1500

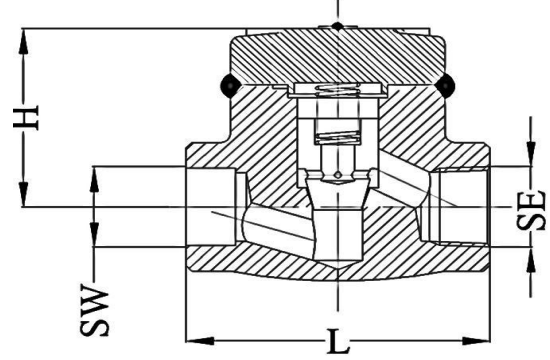
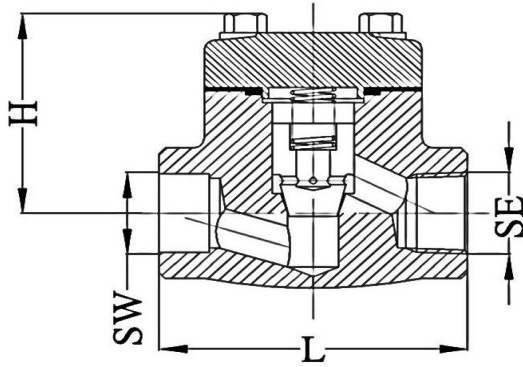

Features and Applications

- Construction :B.C & W.C ,lift check valve
- Gasket:Stainless steel + graphite
- Socket Welding & threaded ends
- Integral seat
- Socket welding dimension :ANSI B 16.11
- Screw end dimension: ANSI B 1.20.1(NPT)
- Design & manufacture : ANSI B16.34,API 602
- Inspect and test: API 598
- Body material: A105,LF2,F5,F11,F22,F304L,F316L
- All dimensions could be considered as reference.

Dimensions

Normal diameter	mm(in)	15(1/2)	20(3/4)	25(1)	32(11/4)	40(11/2)	50(2)
L	mm	92	111	120	152	172	220
H	mm	63	98	104	120	140	158
Weight	Kg	2.0	4.9	6.9	10.8	12	15

info@parsregulator.com
E-MAIL : parsregulator@yahoo.com

www.parsregulator.com

Tel : 88 30 77 66
Fax: 88 83 41 40

FORGED STEEL VALVE SERIES

S.W (NPT) Wing Check Valve

CL 800

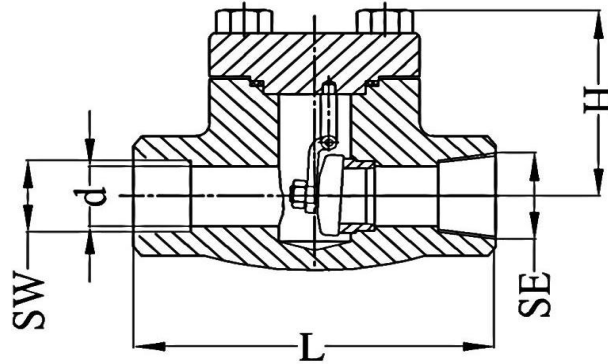

Features and Applications

- Reduced or Full port
- Construction :B.C swing check valve
- Gasket:Stainless steel + graphite
- Socket Welding & threaded ends
- Replaceable hard-faced seats
- Socket welding dimension :ANSI B 16.11
- Screw end dimension: ANSI B 1.20.1(NPT)
- Design & manufacture : API 602, ANSI B 16.34
- Inspect and test: API 598
- Body material: A105,LF2,F5,F11,F22,F304L,F316L
- All dimensions could be considered as reference.

Dimensions

Nominal diameter	Reduced port	mm(in)	15(1/2)	20(3/4)	25(1)	32(11/4)	40(11/2)	50(2)	-
	Full port	mm(in)	10(3/8)	15(1/2)	20(3/4)	25(1)	32(11/4)	40(11/2)	50(2)
d	mm		10	13	18	23	28.5	36	42
L	mm		79	92	111	120	120	140	170
H	Kg		62	63	78	82	1102	120	140
Weight	Kg		1.1	1.2	2.0	3.5	4.5	7.5	10

info@parsregulator.com
E-MAIL : parsregulator@yahoo.com

www.parsregulator.com

Tel : 88 30 77 66
Fax: 88 83 41 40

FORGED STEEL VALVE SERIES

S.W (NPT) Y Type Check Valve

CL 800 & 1500

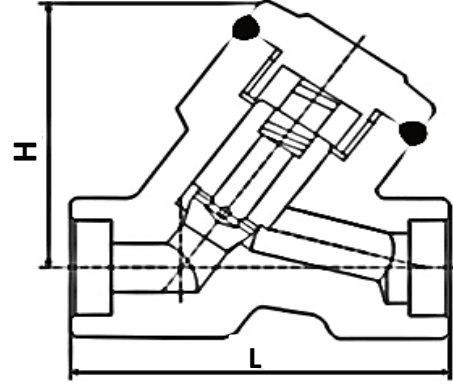
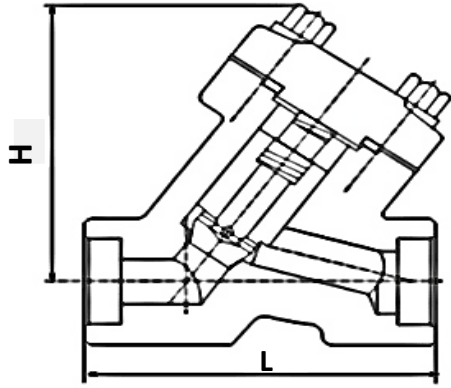

Features and Applications

- Reduced or Full port
- Construction :B.C & W.C
- Y type lift check valve with spring & piston
- Gasket:Stainless steel + graphite
- Socket Welding & threaded ends
- integral seat
- Socket welding dimension :ANSI B 16.11
- Screw end dimension: ANSI B 1.20.1(NPT)
- Design & manufacture : API 602, ANSI B 16.34
- Inspect and test: API 598
- Body material: A105,LF2,F5,F11,F22,F304L,F316L
- All dimensions could be considered as reference.

Dimensions

Nominal diameter		mm(in)	10(3/8)	15(1/2)	20(3/4)	25(1)	32(11/4)	40(11/2)	50(2)
L	CL800	mm	98	98	98	120	140	140	170
	CL1500	mm	120	120	120	140	140	170	220
H	CL800	mm	84	84	84	102	114	115	145
	CL1500	mm	90	90	101	125	132	143	203
Weight	CL800	Kg	3.0	2.9	2.7	6.5	8.5	9.6	10.8
	CL1500	Kg	3.2	3.2	4.1	7.2	10.5	11.6	12

info@parsregulator.com
E-MAIL : parsregulator@yahoo.com

www.parsregulator.com

Tel : 88 30 77 66
Fax: 88 83 41 40

FORGED STEEL VALVE SERIES

S.W (NPT) Y Strainer

CL 800

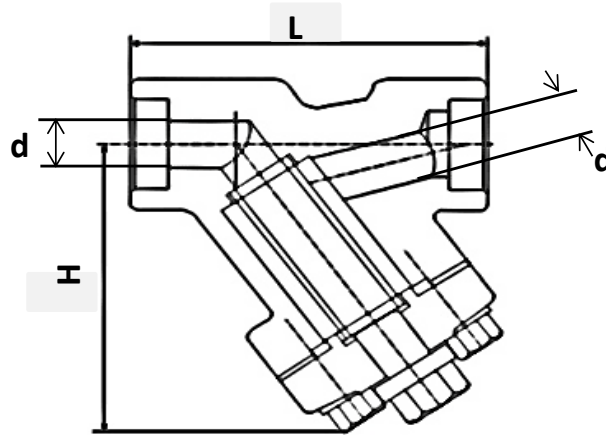

Features and Applications

- Construction :B.C Y Type
- Gasket:Stainless steel + graphite
- Socket Welding & threaded ends
- Socket welding dimension :ANSI B 16.11
- Screw end dimension: ANSI B 1.20.1(NPT)
- Design & manufacture : API 602, ANSI B 16.34
- Inspect and test: API 598
- Body material: A105,LF2,F5,F11,F22,F304L,F316L
- All dimensions could be considered as reference.

Dimensions

Norminal diameter	mm(in)	15(1/2)	20(3/4)	25(1)	32(11/4)	40(11/2)	50(2)
d	mm	11	13	18	23	28	33
L	mm	98	98	120	140	140	170
H	mm	86	86	105	118	120	145
Weight	Kg	2.7	2.5	6.3	8.2	9.2	10.3



FORGE STEEL

GATE, GLOBE & CHECK VALVES

Head Office : 2nd. Floor, No. 46, Karimkhan St. , Tehran-Iran

Tel : +9821 88 30 77 66 Fax: +9821 88 83 41 40

Email: info@parsregulator.com
parsregulator@yahoo.com

Factory #1: No.263 , West Danesh St. , Sarasiab Malard , Karaj-Iran

Tel.: +9821 65 16 20 25 fax: +9821 65 16 20 24

WWW.PARSREGULATOR.COM